



RACO-ELECTRIC CYLINDER®

MODULAR SYSTEM – HEAVY DUTY SERIES (TYPE 1) SIZE 4,5,6,7,8

HIGH-PERFORMANCE ELECTRIC CYLINDERS: ROBUST, RELIABLE AND FLEXIBLE RETRO-FITTING

The RACO actuator system is of modular design, and thus enables the combination of the most important integral elements of the electric cylinder such as the spindle-nut system, the gearbox, the electric motor and the sensors. This versatility opens up a wide range of applications for the RACO electric cylinder type 1.

Depending on the application in question, the suitable thrust-retraction unit of the electric cylinder can be equipped with a DC motor, AC motor, step motor or servo-motor. The performance data listed in the table refer to the version with a RACO 3-phase motor, which can be optionally fitted with a frequency converter. This motor can also be fitted with a parking brake and / or manual adjustment device.

In order to meet the requirements of every installation situation, various attachment points are provided on the electric cylinder for fitting to the construction or the on-site foundations.

All interfaces are provided for the adaptation of various sensor



components such as limit switches, rotary impulse encoders, position transmitter, distance measurement systems and force measurement systems. The corresponding electronic assemblies are also available for the actuation of the electric cylinders.

The configuration of these proven components in accordance with specific customer technical conditions guarantees a high level of operating safety and reliability for every individual RACO electric cylinder.

Performance data, dimensions and weights for actuator size 4 (max. 2,5 kN) up to size 8 (max. 100 kN)

For technical details about size 9 (max. 160 kN) up to size 11 (max. 1000 kN) please refer to catalogue 3.1.1.

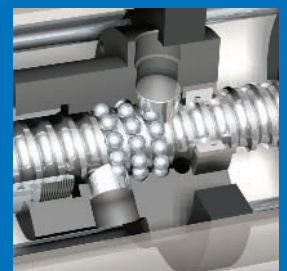
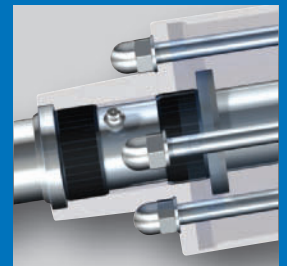

RACO-ELECTRIC CYLINDER®

MODULAR SYSTEM – HEAVY DUTY SERIES (TYPE 1) GENERAL INFORMATION

THE RACO ELECTRIC CYLINDER

The actuators of this series are very robust, and as a sealed system protected against the ingress of dirt are particularly suitable for use under high-stress conditions. Even under the most difficult conditions, constant stroke speed and high positioning accuracy is ensured. Many thousands of RACO electric cylinders have already proven themselves to remain highly accurate and reliable under extreme operating conditions such as heat, cold, dust and humidity.

Features & Benefits:

- High force, long stroke and high speed available to fit your individual needs
- Solid construction principle with high class material for all kinds of applications
- High reliability even under extreme operating conditions
- Highest positioning accuracy and reproduction of former values
- High shifting frequencies and high dynamic movement
- All sizes with trapezoidal, multiple-speed trapezoidal thread spindles or ball screws
- Long-term lubrication with internal grease depot for anticipated working life
- Totally enclosed system optional with special sealing and corrosion protection
- Many options for the actuator control

The mechanical thrust-retraction unit consists of a spindle-nut system with modified thrust tube, which is installed in a sealed housing. The cylinder housing is constructed of alloy or steel, depending on the size of the unit, and can optionally be given an inner coating for increased corrosion protection. The thrust tubes are coated with a special permanent hard-chrome plating, or are optionally available in stainless or rustproof material. Two standard **spindle types** are available for the spindle-nut system:

The **trapezoid threaded drive** consists of a spiral or optional ground spindle in combination with a spindle nut of special bronze. Depending on the choice of spindle geometry and drive, this version can also provide a self-restricting capability. Even high static stresses well above the nominal setting force can be reliably held in any intermediate position. Multiple

trapezoid spindles and / or larger spindle pitches can optionally be used in order to increase the setting speeds.

The **ball screw drive** has no self-restricting capability, since only little friction occurs between the nut and spindle due to the roller contact between the balls and runners. This causes less wear than in a threaded spindle, which under the same operating conditions therefore results in the longer working life of the ball threaded drive. This spindle type is therefore particularly suitable for applications requiring a high degree of precision for the positioning and repetition accuracy.

Depending on the installation position of the RACO motor, the modular design enables (with or without gearbox) 3 different **basic designs** (A/M = straight, C/N = parallel, T = angled).

Extract from the RACO type code:

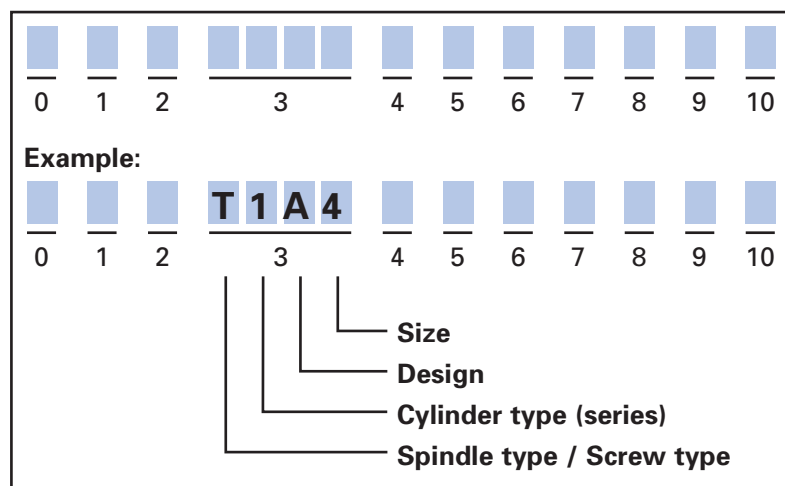

RACO-ELECTRIC CYLINDER®

MODULAR SYSTEM – HEAVY DUTY SERIES (TYPE 1) TECHNICAL INFORMATION

Features:

- Screw incl. internal torque support of the nut
- Hard chromate plated push pull unit with rod eye clevis
- Front cap double sealed and with ice wiper
- AC motor or gear motor with brake
- Motor optional with hand wheel for manual emergency operation
- Limit switches and position transmitter in a sealed housing
- Integrated shock absorbing system and torque switch

RACO 3-phase motors

The electric cylinders are equipped with the latest generation of RACO motors, which are available as three-phase AC motors or as AC motors. The 2-, 4-, 6- and 8-polar motors are available in different designs and capacities up to 4.0 kW.

All RACO motors of this series are equipped with a thermo-contact and are suitable for frequency converter operation. Due to RACO's specific modular system a number of sensor options are additionally available to the user, thus enabling fine tuning of the motor to specific customer applications.

Motor performance / switching frequency

The motor performances for the operation in relation to the corresponding switching time are

listed in the tables for the electric cylinders with trapezoid or ball screw drive.

Since the electric cylinders with 3-phase motors are actuated in offset operation, the switching frequency in relation to permissible warming is decisive for the engineering and design.

Converter operation

In converter operation, it should be noted that as a result of the upper wave content of the voltage, the frequency converter leads to increased losses in the motor, which are all the lower the better the output voltage of the converter is adapted to the sinus form. Depending on the speed setting range, counter-torque progression, load play and converter type, the possible performance reduction and choice of cooling method must be taken into account. RACO motors should basically be operated as a maximum from 500 V, 50 Hz power supply systems, taking into account the voltage load on the insulation system by the converter.

The operating method of the motors in converter operation must be adapted to the non-ventilated design, i.e. higher load torques at low speeds can in the case of long running times lead to impermissible heating and actuation of the thermo-switch. The use of an optionally available thermistor is recommended. The corresponding type of operation should be taken into account in the form of higher designed performance or a ventilated version.

Position sensors

The electro-mechanical setting drives must not be moved to the mechanical end-position, but must be stopped reliably within the available usable stroke by the controls on reaching the end-position switches. For electric cylinders of cylinder type 1, additional equipment housings are available with up to 6 adjustable, mechanically operated change-over switches (Type: ME) and an electronic position encoder (Type: DMU) for signalling the end positions and / or intermediate positions.

Alternatively, RACO also offers a contactless, electronic sensor, which includes further functions in addition to the end-switch functionality. Two fixed positions can be specified by means of a "teach-in" mode with the aid of the electronic position sensor (Type: EPS02). In contrast to the basic variant, the electronic position sensor (Type: EPS06) offers 4 further switch functions, speed (revolutions) monitoring and an analogue signal for the actual position value. The impulses can also be evaluated in the same way as an incremental encoder. Exact modification of the drive to the customer application can quickly be carried out on site.

Force sensors

For the overload monitoring as well as security switch off a torque sensor can be implemented in the system on request.

RACO-ELECTRIC CYLINDER®

MODULAR SYSTEM – HEAVY DUTY SERIES (TYPE 1) TECHNICAL DATA

Technical performance data for electric linear actuators, design A-M-C-N-T with trapezoidal screw: T1__

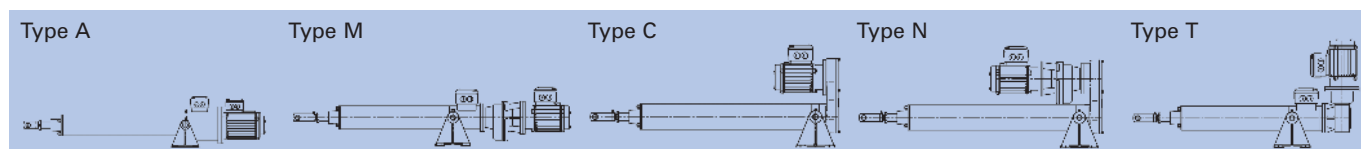

Size	Thrust unit Stroke (mm)	Dimension a ₃ (mm)	Selection	Force (kN)	Speed ca. (mm/s)	Type A			Type M			Type C			Type N			Type T				Nom. current I _N (A)	No. of poles	
						a ₅ max. (mm)	l ₃ ** (mm)	Motor power (kW)	a ₅ (mm)	l ₂ ** max. (mm)	Motor power (kW)	a ₁₀ (mm)	u ₃ (mm)	Motor power (kW)	a ₁₀ (mm)	u ₃ (mm)	Motor power (kW)	a ₅ (mm)	l ₀ (mm)	l ₁ ** max. (mm)	Motor power (kW)			
4	100	430	}	5,0	5			126	375	0,12				15	73	0,12	126	145	306,5	0,12	0,3	8		
	200	530			10			126	375	0,25				15	73	0,25	126	145	306,5	0,25	0,7	4		
	300	630			15			126	375	0,25	15	73	0,25	15	73	0,25	126	145	306,5	0,25	0,8	4		
	400	730			20						15	73	0,25								1,5	8		
	500	830		30			126	375	0,37											1,5	4			
	600	930		15	2,5	15					15	73	0,12									0,9	8	
	800	1130		30		134	233	0,25			15	73	0,25								1,6	8		
	1000	1330		65		134	205	0,37			15	73	0,37								2,0	4		
5	100	455	}	10,0		5			135	375	0,25				18	116	0,25	135	155	308,5	0,25	1,0	4	
	200	555			10			135	375	0,37				18	116	0,37	135	155	308,5	0,37	1,0	4		
	300	655			15			135	401	0,55				18	116	0,55	135	155	334,5	0,55	2,0	4		
	400	755			15						18	116	0,55								3,0	8		
	500	855		30			135	388	1,1				18	116	1,1					3,5	4			
	600	955		30						18	116	0,75								4,0	6			
	800	1155		40	5,0	40	148	240	0,55				18	116	0,55						3,0	8		
	1000	1355		60		148	218	0,75			18	116	0,75							2,3	6			
		90	148	240		1,1			18	116	1,1							3,5	4					
6	200	670	}	20,0	5			157	375	0,37				27	116	0,37	160	155	322,5	0,37	1,2	4		
	400	870			10			157	401	0,75				27	116	0,75	160	155	349	0,75	2,3	4		
	600	1070			20			157	388	1,1				27	116	1,1	160	194	335,5	1,1	3,0	4		
	800	1270			30			157	410	1,5				27	116	1,5					5,5	4		
	1000	1470		30						27	116	1,5								4,7	8			
	1200	1670		60	10,0	60	167	324	1,5				27	116	1,5						4,1	8		
	1400	1870		60							27	116	1,5								4,5	4		
	1600	2070		110		167	324	3,6			27	116	3,6							8,5	4			
7	200	745	}	50,0	5			228	433	0,75				48	116	0,75	225	194	381	0,75	2,3	6		
	400	945			10			228	455	1,5				48	116	1,5	225	194	390	1,5	5,0	4		
	600	1145			15			228	509	2,2				48	116	2,2	225	194	444	2,2	5,0	4		
	800	1345			30			228	539	3,0				48	116	3,0	225	194	474	3,0	9,5	4		
	1000	1545		30	40,0																			
	1200	1745		60				228	573	4,0				48	116	4,0					15,6	4		
	1400	1945				30,0																		
	1600	2145		80					228	573	4,0				48	116	4,0					13,0	4	
1800	2345		20,0																					
2000	2545																							
8	200	780	}	100,0	5			260	459	1,5				90	155	1,5	270	214	487	1,5	4,8	4		
	400	980			5			260	459	1,1				90	155	1,1	270	214	465	1,1	4,8	4		
	600	1180			10			260	535	2,2				90	155	2,2	270	214	541	2,2	7,6	4		
	800	1380			15			260	599	4,0				90	155	4,0	270	242	605	4,0	10,0	4		
	1000	1580			80,0																			
	1200	1780		5				260	459	0,75				90	155	0,75	270	214	465	0,75	2,9	6		
	1400	1980		10				260	535	1,5				90	155	1,5	270	214	487	1,5	5,0	4		
	1600	2180		15				260	535	2,2				90	155	2,2	270	214	541	2,2	7,0	4		
1800	2380		60,0																					
2000	2580	30				260	599	4,0				90	155	4,0	270	242	605	4,0	8,5	4				

Note: For size 6 a stroke up to 2000mm is available! Any special stroke for all sizes on request. The stroke can be freely selected for all mentioned forces in combination with the corresponding speed.

Motor: The standard connection voltage is 230/400 V AC, 50 Hz! The basic version of the RACO motors of series 4 - 8 is the non-ventilated motor with B5-flange diameter of 140 mm or 200 mm at the front, and (brake) bearing plate at the rear for installation of other RACO devices. Metric threads for cable screw connections are provided in the junction box.

Protection type: All new RACO motors are supplied with IP 54 protection. Motors with increased protection types (IP 65) optional.

Note: Since the self-restricting capability of the electric cylinder with trapezoid thread drive can be cancelled out under certain circumstances, such as vertical installation with a suspended load and/or vibrations, a brake is recommended.

RACO-ELECTRIC CYLINDER®

MODULAR SYSTEM – HEAVY DUTY SERIES (TYPE 1) TECHNICAL DATA

Technical performance data for electric linear actuators, design A-M-C-N-T with ball screw: K1__

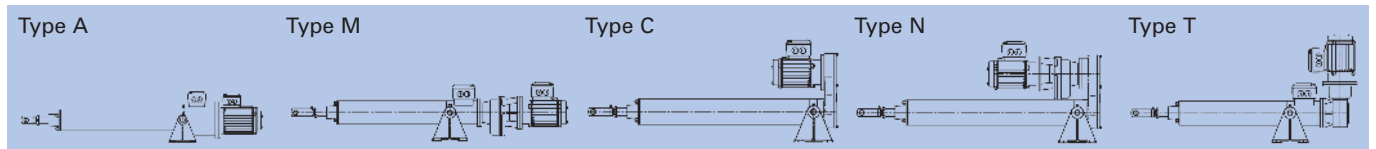

Size	Thrust unit Stroke (mm)	Dimension a ₃ (mm)	Selection	Force (kN)	Speed ca. (mm/s)	Type A			Type M			Type C			Type N			Type T				Nom. current I _N (A)	No. of poles
						a ₅ max. (mm)	l ₃ ** (mm)	Motor power (kW)	a ₅ (mm)	l ₂ ** max. (mm)	Motor power (kW)	a ₁₀ (mm)	u ₃ (mm)	Motor power (kW)	a ₁₀ (mm)	u ₃ (mm)	Motor power (kW)	a ₅ (mm)	l ₀ (mm)	l ₁ ** max. (mm)	Motor power (kW)		
4	100	430	}	5,0	5			126	375	0,12				15	73	0,12	126	145	306,5	0,12	0,3	8	
	200	530			10			126	375	0,12					15	73	0,12	126	145	306,5	0,12	0,7	8
	300	630			15			126	375	0,12					15	73	0,12	126	145	306,5	0,12	0,7	8
	400	730			30			126	375	0,37					15	73	0,37					2,1	4
	500	830			30							15	73	0,25								1,2	8
	600	930			60			126	375	0,25	15	73	0,25	15	73	0,25						0,9	4
	800	1130			120	134	231	0,37				15	73	0,37								2,0	4
	1000	1330																					
5	100	455	}	10,0	5			195	375	0,12				18	116	0,12	135	155	308,5	0,12	0,3	8	
	200	555			10			195	375	0,25					18	116	0,25	135	155	308,5	0,25	0,7	4
	300	655			15			195	375	0,25					18	116	0,25	135	155	308,5	0,25	0,9	4
	400	755			30			195	375	0,37					18	116	0,37	135	155	308,5	0,37	1,4	4
	500	855			40							18	116	0,55								2,5	8
	600	955			90	148	240	0,55				18	116	0,55								2,5	8
	800	1155			120							18	116	0,75								3,0	4
	1000	1355			180	148	218	1,1				18	116	1,1								3,0	4
6	200	670	}	20,0	5			157	375	0,25				27	116	0,25	160	155	323	0,25	0,7	4	
	400	870			10			157	375	0,37					27	116	0,37	160	155	322,5	0,37	1,0	4
	600	1070			15			157	401	0,37					27	116	0,37	160	194	322	0,37	1,4	4
	800	1270			30			157	401	0,75					27	116	0,75					2,5	4
	1000	1470			60			157	401	0,75					157	116	0,75					2,5	4
	1200	1670			110	167	324	1,5														5,0	8
	1400	1870			110							27	116	1,5								4,2	4
	1600	2070			200	167	324	3,0				27	116	3,0								9,0	4
7	200	745	}	40,0	5			228	420	0,37				48	116	0,37	225	194	335	0,37	1,3	4	
	400	945			10			228	446	0,75					48	116	0,75	225	194	381	0,75	2,2	4
	600	1145			15			228	446	0,75					48	116	0,75	225	194	381	0,75	3,0	4
	800	1345			30			228	455	1,5					48	116	1,5	225	194	390	1,5	5,5	4
	1000	1545			60			228	455	1,5					48	116	1,5					5,5	4
	1200	1745			130			228	510	2,2	48	116	2,2									7,0	4
	1400	1945			180						48	116	4,0									10,0	4
	2000	2545																					
8	200	780	}	100,0	10			260	459	1,1				90	155	1,1	270	214	465	1,1	3,5	4	
	400	980			5			260	481	0,55					90	155	0,55	270	214	465	0,55	5,0	8
	600	1180			15			260	481	1,5					90	155	1,5	270	214	487	1,5	5,0	4
	800	1380			25			260	535	2,2					90	155	2,2	270	214	541	2,2	9,0	4
	1000	1580			5			260	481	0,55					90	155	0,55	270	214	487	0,55	2,0	8
	1200	1780			15			260	459	1,1					90	155	1,1	270	214	465	1,1	3,7	4
	1400	1980			25			260	535	1,5					90	155	1,5	270	214	541	1,5	7,0	4
	1600	2180			60			260	565	3,0					90	155	3,0					9,5	4
	1800	2380			80			260	599	4,0					90	155	4,0					12,5	4
	2000	2580																					

Note: For size 6 a stroke up to 2000mm is available! Any special stroke for all sizes on request. The stroke can be freely selected for all mentioned forces in combination with the corresponding speed. * Not self-locking, brake "L" recommended. ** including end cover of 25mm, delete when accessory housings A, B or C are used, Length of motor without brake!

Insulation class: The insulation systems of machinery must be allocated to a heat class according to IEC 85. The motors are available in heat class F, or at an extra price in heat class H.

Special version: In the tropical protection version, the copper winding is impregnated with a special coating.

Note: Other performance data are also possible following review of specific customer requirements. At high setting speeds, the run-on, which affects the usable stroke, is reduced by means of a brake.

RACO-ELECTRIC CYLINDER®

MODULAR SYSTEM – HEAVY DUTY SERIES (TYPE 1) DIMENSIONS, DESIGNS AND COMPONENTS

Rear accessory housings type A, B, C
for type A, M, C, N, T

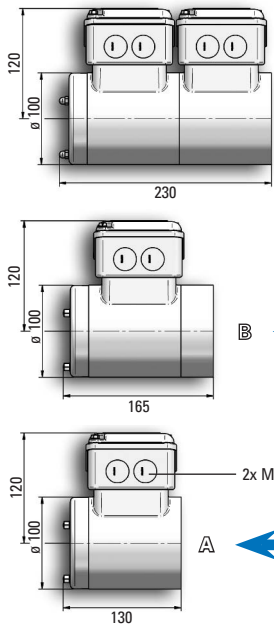

Motor for Type C

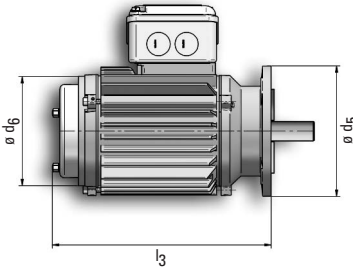

Helical geared motor for type N

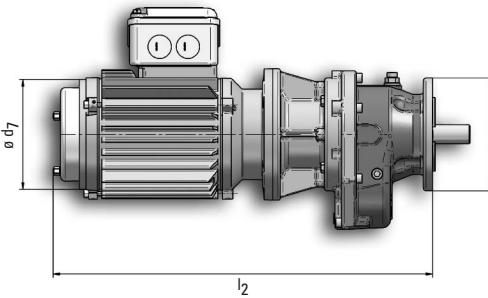

Lateral accessory housing F for type A, M, T



Lateral accessory housing D for type A, M, T

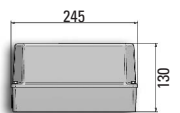

F

D

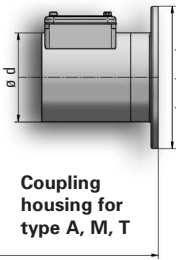

Coupling housing for type A, M, T

Thrust unit for type A, M, C, N, T

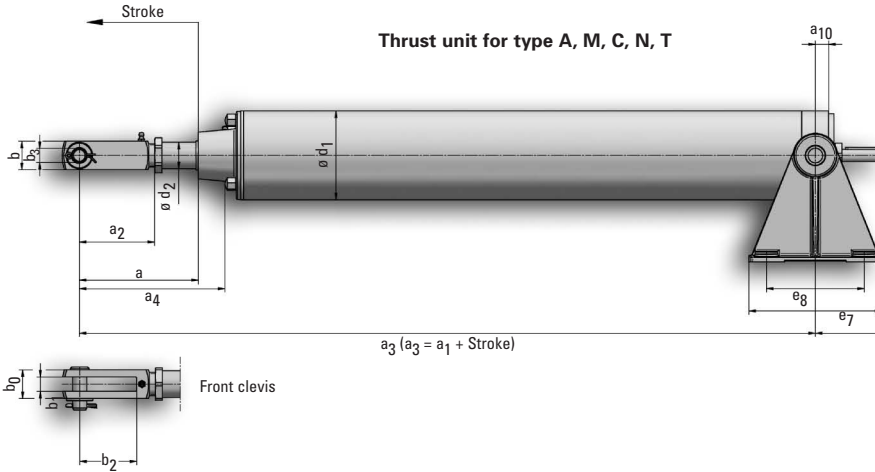

Dimensions (mm)

Size	Length EZ						Front clevis / Spherical eye rod end							Diameter EZ / Diameter Motors									Front flange mounting								
	a	a ₁	a ₂	a ₃	a ₄	a ₁₀	b	b ₀	b ₁	b ₂	b ₃	b ₄	b ₅	b ₆	b ₇	d	d ₁	d ₂	d _{3max}	d _{4max}	d _{5max}	d _{6max}	d _{7max}	d ₈	d ₉	d ₁₀	d ₁₁	d ₁₂	d ₁₃	t ₁	t ₂
4	132	330	92	330 + Hub	163	15	32	32	16	64	16	42	16	21	15	100	100	30	120	120	140	138	122	125	127	200	165	130	4x11	3	14
5	123	355	73	355 + Hub	162	18	40	40	20	40	20	64	25	20	17	171	114	40	160	160	200	155	122	158	171	200	165	130	4x13	3	15
6	180	470	112	470 + Hub	222	27	56	56	28	56	28	73	30	22	19	171	140	50	200	160	200	196	155	196	219	250	215	180	4x13	4	16
7	183	545	105	545 + Hub	219	48	80	80	32	60	40	116	50	35	40	171	180	60	200	160	200	196	196	196	219	300	265	230	8x14	4	20
8	192	580	105	580 + Hub	229	90						116	50	35	40	200	220	100	250	250			196	196	219	350	300	250	8x18	5	20

RACO-ELECTRIC CYLINDER®

MODULAR SYSTEM – HEAVY DUTY SERIES (TYPE 1) DIMENSIONS, DESIGNS AND COMPONENTS

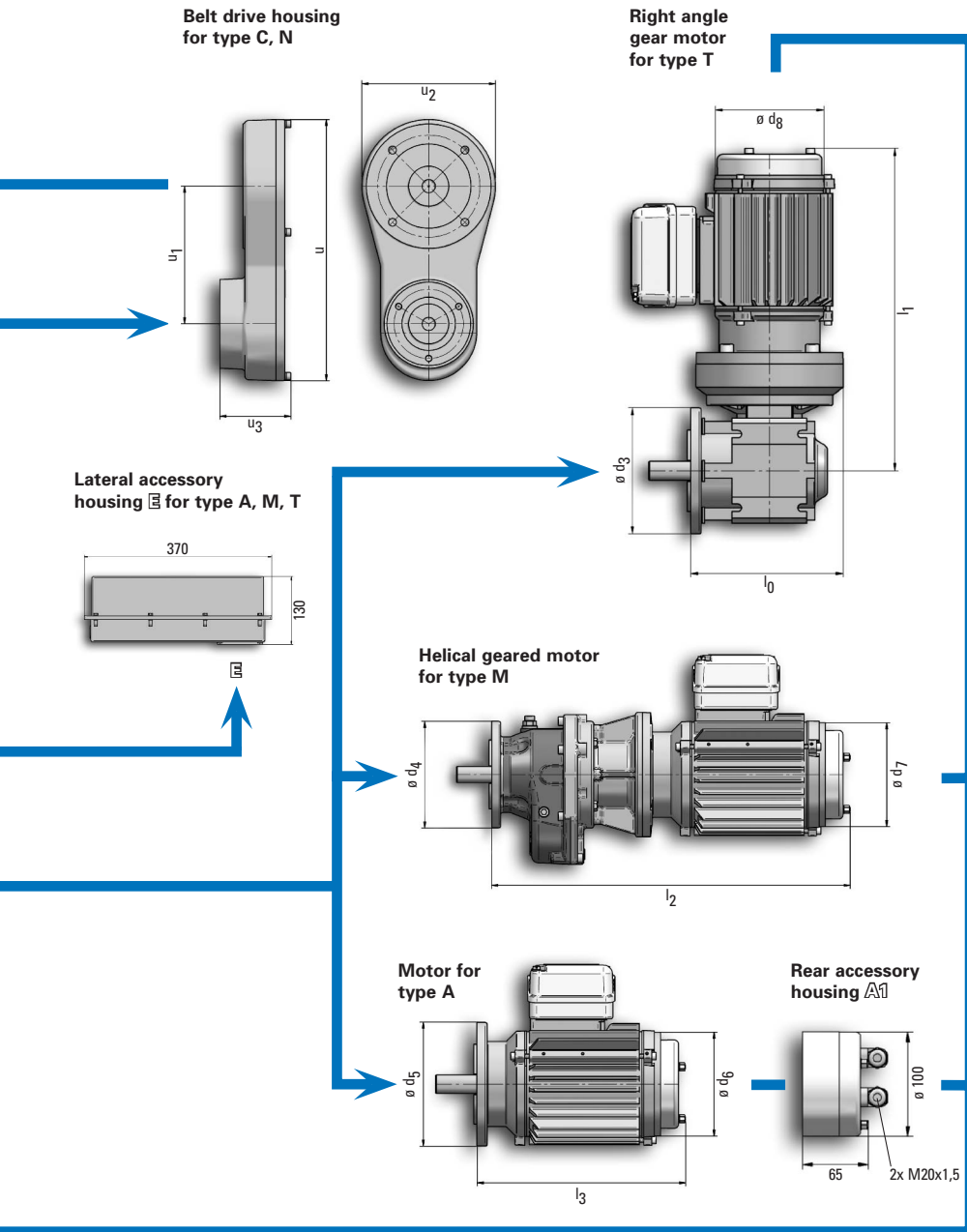

Optional equipment

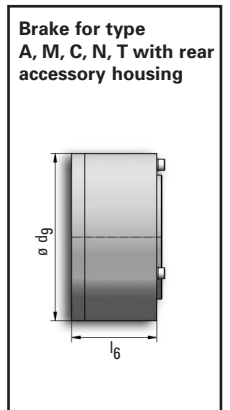
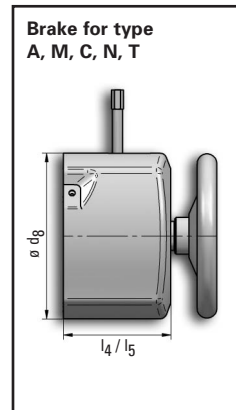
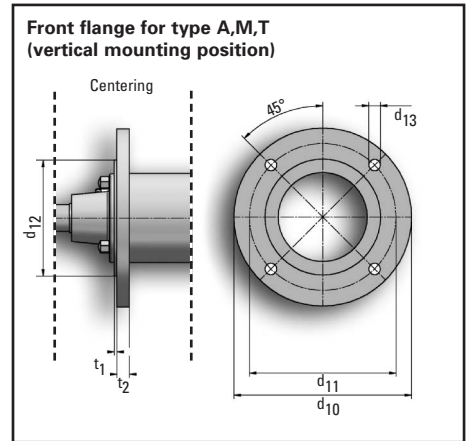
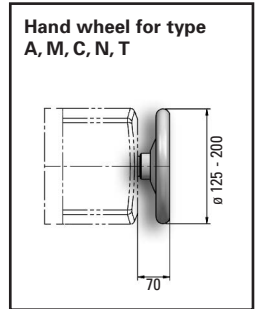
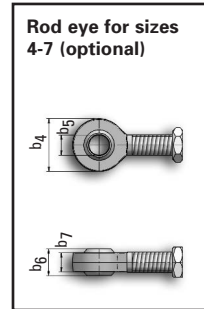
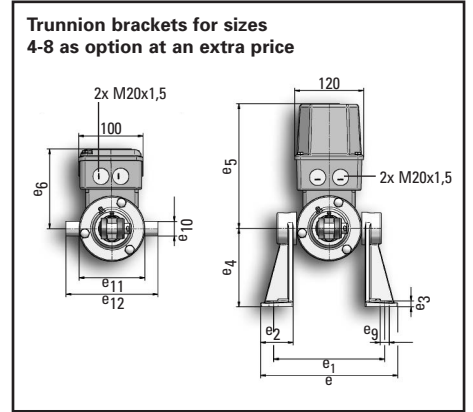

Size	Trunnion brackets												Brake			Drive housing				
	e	e ₁	e ₂	e ₃	e ₄	e ₅	e ₆	e ₇	e ₈ *	e ₉	e ₁₀	e ₁₁	e ₁₂	l ₄	l ₅	l ₆	u	u ₁	u ₂	u ₃
4	210	170	50	8	120	190	120	150	110	14	22	100	140	82	82	63	294	155	150	73
5	285	245	50	8	120	223	152	150	110	14	30	175	235	105	128	101	405	200	210	116
6	325	265	70	12	160	223	152	260	200	18	40	175	255	123	163	123	405	200	210	116
7	350	290	70	12	160	223	152	260	200	18	40	200	282	123	163	123	405	200	210	116
8	415	355	80	12	200	250	180	240	100	18	50	245	345	123	163	123	580	343	210	155

*Size 8 with 4 holes

RACO-ELECTRIC CYLINDER®

**MODULAR SYSTEM – HEAVY DUTY SERIES (TYPE 1)
WEIGHTS AND WIRING DIAGRAM**

Weights (kg)

Type	Stroke (mm)														trunnion brackets (1 pair)	Brake	Rear accessory housing					
	100	200	300	400	500	600	800	1000	1200	1400	1600	1800	2000	A			B	C	D	E	F	
Y4	6	7	8	9	10	11	13	15						1,2				2	5	0,7		
A4	14	15	16	17	18	19	21	23						1,2	2	2	2,5	3,5	2	5	0,7	
M4	25	26	27	28	29	30	32	34						1,2	2	2	2,5	3,5	2	5	0,7	
C4	16	17	18	19	20	21	23	25						1,2	2	2	2,5	3,5				
N4	27	28	29	30	31	32	34	36						1,2	2	2	2,5	3,5				
T4	20	21	22	23	24	25	27	29						1,2	2	2	2,5	3,5	2	5	0,7	
Y5	9	12,5	16	19,5	23	26,5	33,5	40,5						2,5					2	5	0,7	
A5	29	32,5	36	39,5	43	46,5	53,5	60,5						2,5	5	2	2,5	3,5	2	5	0,7	
M5	28	31,5	35	38,5	42	45,5	52,5	59,5						2,5	2	2	2,5	3,5	2	5	0,7	
C5	31	34,5	38	41,5	45	48,5	55,5	62,5						2,5	2	2	2,5	3,5				
N5	30	33,5	37	40,5	44	47,5	54,5	61,5						2,5	5	2	2,5	3,5				
T5	23	26,5	30	33,5	37	40,5	47,5	54,5						2,5	2	2	2,5	3,5	2	5	0,7	
Y6		33		41,5		50	58,5	67	75,5	84	92,5	101	109,5	10					2	5	0,7	
A6		53		61,5		70	78,5	87	95,5	104	112,5	121	129,5	10	5	2	2,5	3,5	2	5	0,7	
M6		64		72,5		81	89,5	98	106,5	115	123,5	132	140,5	10	5	2	2,5	3,5	2	5	0,7	
C6		56		64,5		73	81,5	90	98,5	107	115,5	124	132,5	10	5	2	2,5	3,5				
N6		67		75,5		84	92,5	101	109,5	118	126,5	135	143,5	10	5	2	2,5	3,5				
T6		63		71,5		80	88,5	97	105,5	114	122,5	131	139,5	10	5	2	2,5	3,5	2	5	0,7	
Y7		69		79		89	99	109	119	129	139	149	159	10					2	5	0,7	
A7		89		99		109	119	129	139	149	159	169	179	10	6	2	2,5	3,5	2	5	0,7	
M7		108		118		128	138	148	158	168	178	188	198	10	5	2	2,5	3,5	2	5	0,7	
C7		92		102		112	122	132	142	152	162	172	182	10	6	2	2,5	3,5				
N7		111		121		131	141	151	161	171	181	191	201	10	5	2	2,5	3,5				
T7		107		117		127	137	147	157	167	177	187	197	10	5	2	2,5	3,5	2	5	0,7	
Y8		127		141		155	169	183	197	211	225	239	253	15					2	5	0,7	
A8																						
M8		173		187		201	215	229	243	257	271	285	299	15	5	2	2,5	3,5	2	5	0,7	
C8																						
N8		184		198		212	226	240	254	268	282	296	310	15	5	2	2,5	3,5				
T8		178		192		206	220	234	248	262	276	290	304	15	5	2	2,5	3,5	2	5	0,7	

Wiring diagram for the RACO 3-phase motor

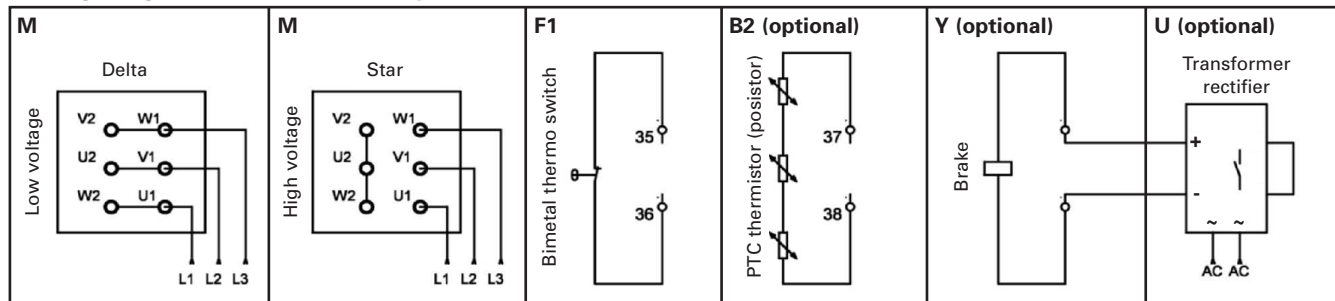

EZ 3.1.0e P2 02/08 (143-286-9) Our in house application engineers will assist you with your application. Call us.

© COPYRIGHT RACO, February 2008. Technical innovations and or modifications are subject to be changed without notice.

RACO Elektro-Maschinen GmbH

Jesinghauser Str. 56-64
58332 Schwelm / Germany
Tel: +49 2336 40 09-0
Fax: +49 2336 40 09-10
eMail: raco@raco.de
www.raco.de

Certified acc. DIN EN ISO 9001.